

Section VI

Models 1690 and 1691 Expanders Replacement Parts

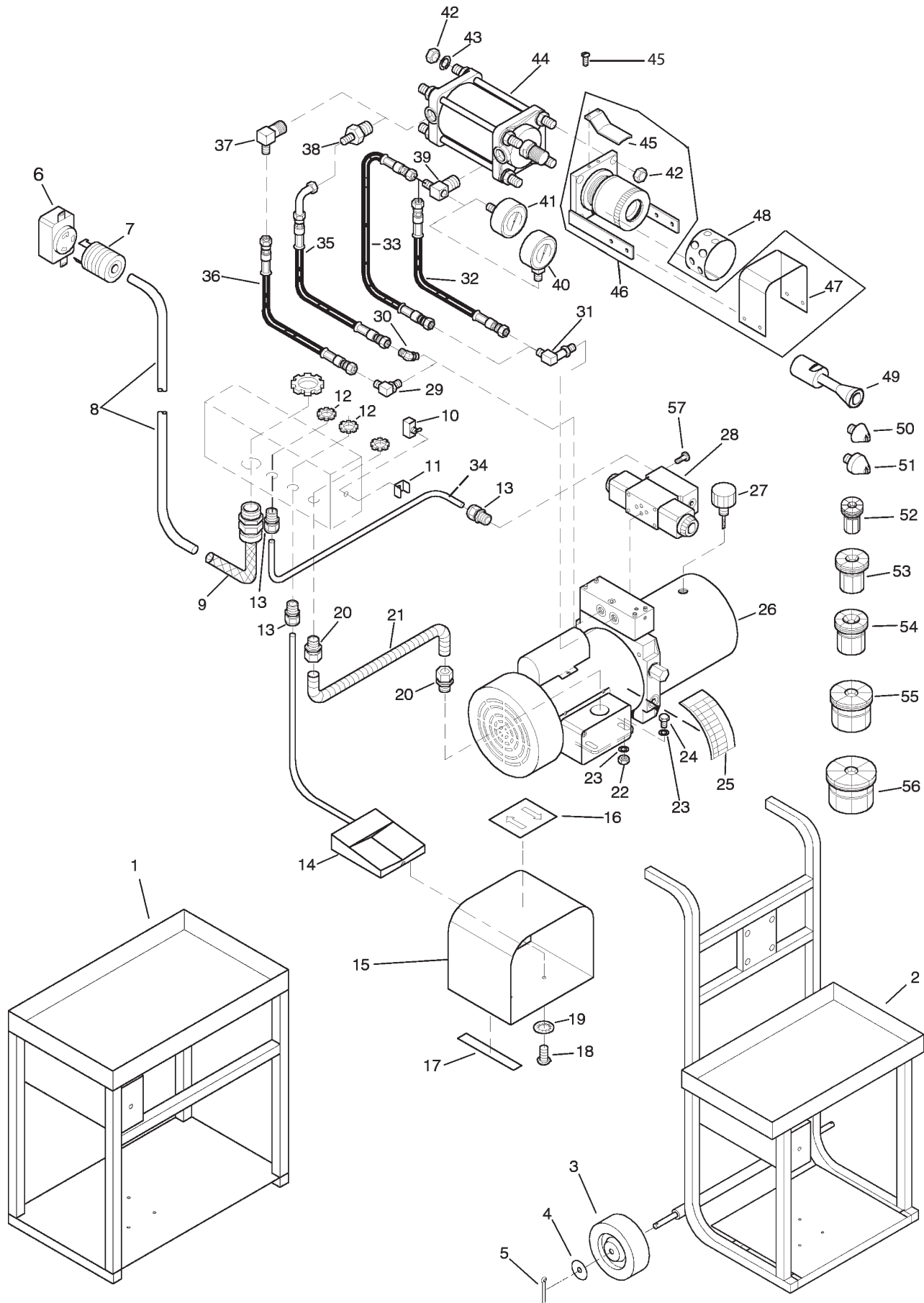

Models 1690 and 1691 Expanders Replacement Parts

KEY	PART NO.	DESCRIPTION
1	97010	Benchtop Frame Model 1690
2	97011	Cart Frame Model 1691
3	97059	Wheel
4	97333	1/2" Flat Washer
5	97334	1/2" x 2" Cotter Pin
6	95190	Receptacle - 110V, 30A
	95188	Receptacle - 220V, 20A
7	95189	Plug - 110V, 30A
	95187	Plug - 220V, 20A
8	95370	10-3 Cord - Sold by the foot. 10' - 1690; 15' - 1691
9	95172	Kellum
10	95087	Toggle Switch
11	95091	Toggle Switch Cover
12	95429	Lock Nut
13	95449	Cord Grip
14	95419	Foot Pedal
15	95102	Foot Pedal Guard
16	98036	Direction Label
17	50058	Rubber Foot
18	97283	6 - 32 x 1/2" Screw
19	97285	6 - 32 Star Washer
20	95229	1/2" Straight Conduit Connector
21	95230	1/2" x 8" Conduit
22	97210	1/4" - 20 Locknut
23	97395	1/4" Flat Washer
24	97260	1/4" - 20 x 3/4" Hex Bolt
25	98042	Sizing Chart
26	1617	Power Unit
27	838	Breather Cap
28	92171	Directional Valve, 110V
	92164	Directional Valve, 220V
29	92071	90° O-Ring Fitting, 3/8" St. Thread x 3/8" JIC Model 1691
30	92066	45° O-Ring Fitting, 3/8" St. Thread x 3/8" JIC Model 1690
31	92065	90° O-Ring Fitting, 3/8" St. Thread x 3/8" JIC Extra Long
32	92265	1/4" 2-Wire, 5,000 PSI 3/8" Female Swivel Hose 16" Long Model 1690
33	92271	1/4" 2-Wire, 5,000 PSI 3/8" Female Swivel Hose 30" Long Model 1691
34	95508	16-3 Cord, 30" (Sold by the inch)
35	92298	1/4" 2-Wire, 5,000 PSI 3/8" Female Swivel- 3/8" Female 90° Swivel Hose, 13", Model 1690
92270	1/4" 2-Wire, 5,000 PSI 3/8" Female Swivel Hose 24" Long Model 1691	36
37	92009	90 Ftg, 1/2ML NPT x 3/8ML JIC Model 1691
38	92002	Str. Ftg., 1/2" ML NPT x 3/8" ML JIC Model 1690
39	92009DT	90 Ftg, 1/2ML NPT x 3/8ML JIC, DT
40	92100	Pressure Gauge, Model 1691
41	92099	Pressure Gauge, Model 1690
42	97208	1/2" - 13 Jam Nut
43	97383	1/2" Lock Washer
44	92375	3-1/2" x 3" Expanding Cylinder
45	595	Sight
46	41047	Adjustable Collar (Includes sight and guard, but not decal)
47	41010	Guard Material
48	98043	Calibration Decal
49	508	Arbor, 1-1/2" - 3-1/2"
50	498	Small Arbor Tip, 1-1/2" - 1-3/4"
51	499	Large Arbor Tip, 1-3/4" - 3-1/2"
52	473	Segment Set (Yellow) 1-1/2" - 1-3/4"
53	474	Segment Set (Red) 1-3/4" - 2-1/8"
54	475	Segment Set (Black) 2-1/8" - 2-1/2"
55	476	Segment Set (Green) 2-1/2" - 3"
56	477	Segment Set, 3" - 3-1/2"
57	97268	10 - 24 x 1 1/4" Allen Head Cap Screw